

Weight 70kg/m<sup>2</sup>  
 Module Width 300 - 1250mm  
 Standard Module Height 356 - 3560mm (in 356mm increments)  
 Intermediate heights are available

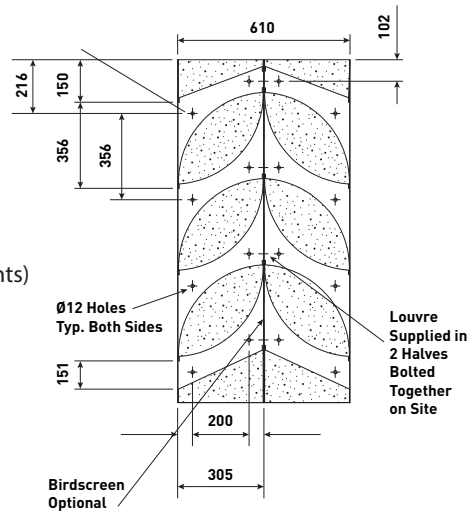

Acoustic Performance

Octave Band Centre Frequency (Hz)	63	125	250	500	1k	2k	4k	8k
Transmission Loss (dB)	5	8	12	16	22	18	15	14
Acoustic Rating	R <sub>w</sub> 19dB / D <sub>new</sub> 25dB							
For noise reduction, add 6dB to the above values								

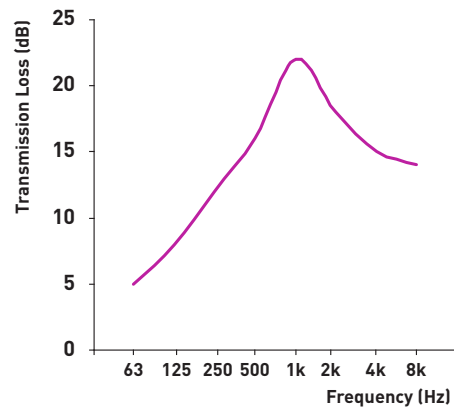

Aerodynamic Performance

Static Pressure Drop (N/m <sup>2</sup> )	10	20	30	40	50	60	70	80	90	100
Face Velocity (m/s)	1.07	1.41	1.73	1.98	2.21	2.46	2.62	2.77	2.99	3.12
Nominal Free Area	52%* * Average over louvre depth									
Cd	0.242									

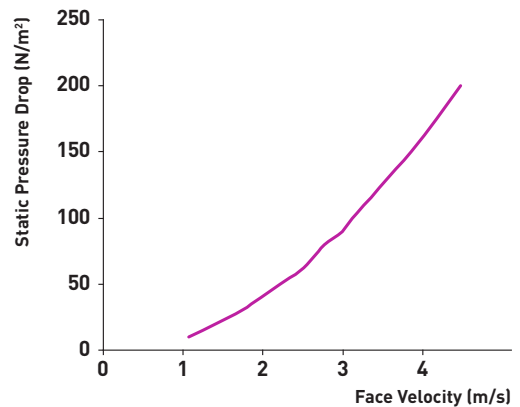

Pressure Drop =  $\dot{m}/Cd$   
 $\dot{m}$  = mass flow  
 Cd = Discharge Coefficient