

Weight 80kg/m<sup>2</sup>  
 Module Width 300 - 1800mm  
 Standard Module Height 305 - 3660mm (in 305mm increments)  
 Intermediate heights are available

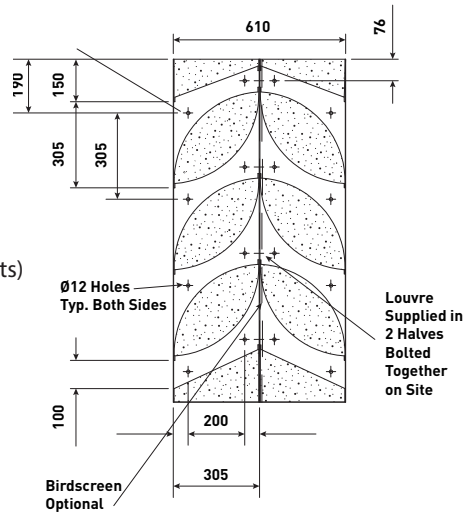

Acoustic Performance

Octave Band Centre Frequency (Hz)	63	125	250	500	1k	2k	4k	8k
Transmission Loss (dB)	6	12	15	21	24	27	25	20
Acoustic Rating	R <sub>w</sub> 24dB / D <sub>new</sub> 31dB							
For noise reduction, add 6dB to the above values								

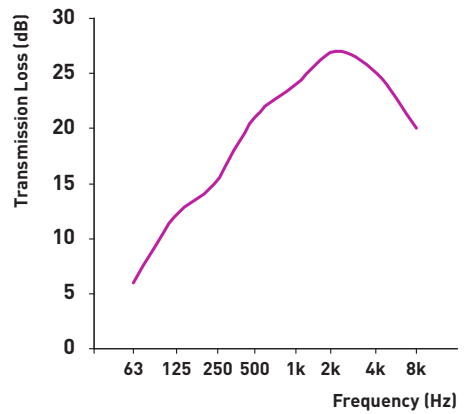

Aerodynamic Performance

Static Pressure Drop (N/m <sup>2</sup> )	10	20	30	40	50	60	70	80	90	100
Face Velocity (m/s)	0.70	1.07	1.21	1.39	1.55	1.68	1.79	1.89	2.01	2.13
Nominal Free Area	43%* * Average over louvre depth									
Cd	0.17									

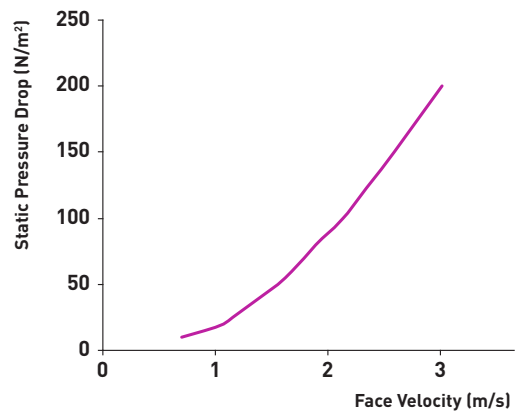

Pressure Drop =  $\dot{m}/Cd$   
 $\dot{m}$  = mass flow  
 Cd = Discharge Coefficient